

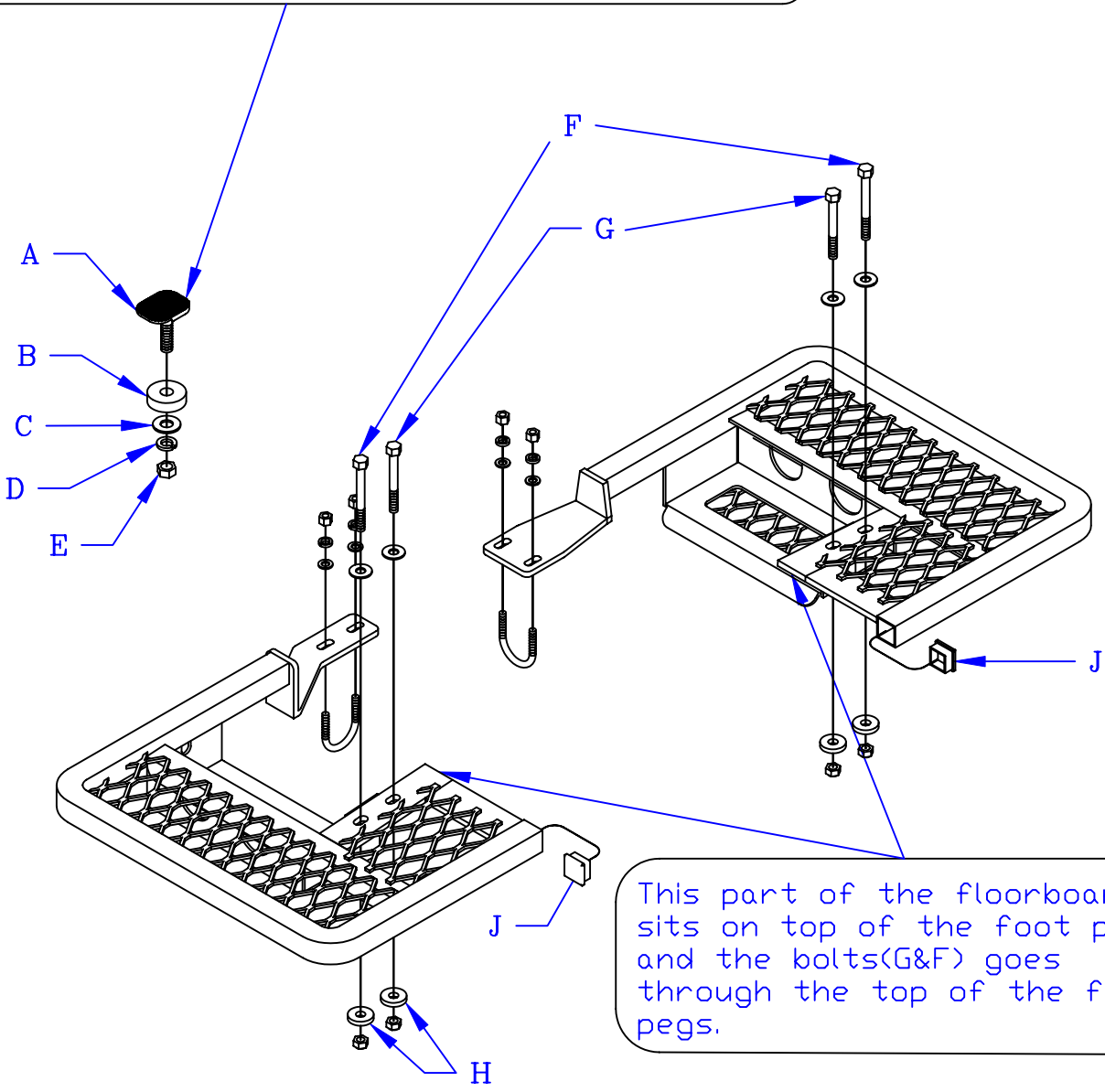

5013

- 4 = 1/4 lock Nuts
- 4 = 5/16 Lock Nuts
- 4 = 1/4 Flat Washers Small (S.A.E.)
- 4 = 5/16 Flat Washers Large (U.S.S.)
- 2 = 5/16 x 3 bolts =G
- 2 = 5/16 X 2 3/4 Bolts =F
- 2 = 1/4 x 1 U-Bolts
- 1 = 7/16 USS Washer = C
- 1 = 7/16 Lock Washer = D
- 1 = 7/16 Nut = E
- 2 = 1" Plugs = J
- 4 = 3/8 hole x 3/16 x 1 Flat Washer = H
- 1 = Brake Extension (Pedal) = A
- 1 = 1/2 ID x 1 1/2 OD x 7/16 Plastic Washer = B

The brake pedal extension (A) and the plastic washer (B) will sit on top of the brake pedal. C,D,E will then bolt up to the bottom of the brake pedal of the bike. When bolting the floorboards in place, make sure there is a 1/8 to a 1/4 gap between the edge of the pocket of the floorboard and the edge of the brake extension. All ways keep the brakes properly adjusted.



This part of the floorboard sits on top of the foot pegs and the bolts(G&F) goes through the top of the foot pegs.