

- 12=1/4 LOCK NUTS-A
- 4=1/4 SAE WASHERS-B
- 6=1/4X1 SQUARE U-BOLTS-C
- 4=3/16X1X3/8 HOLE WASHERS-D
- 2=5/16X1 1/4 BOLTS-E
- 4=5/16 SAE WASHERS-F
- 2=5/16X1/2 U-BOLTS-G
- 6=5/16 LOCK NUTS-H
- 4=1/4 ROD CAPS-I
- 2=1" PLUGS-J
- 1= ALUMIN. WASHERS SLOTS-K
- 1=GR BRACKET L SHAPE-L
- 1= 1" TUB. 19 LONG-M
- 2=FGAR-2-N
- 1=MAIN BRACKET-O
- 4=RUBBER SNUBBERS-P



#GR123

KAWASAKI 650 V-TWIN

PACK IN BOX,

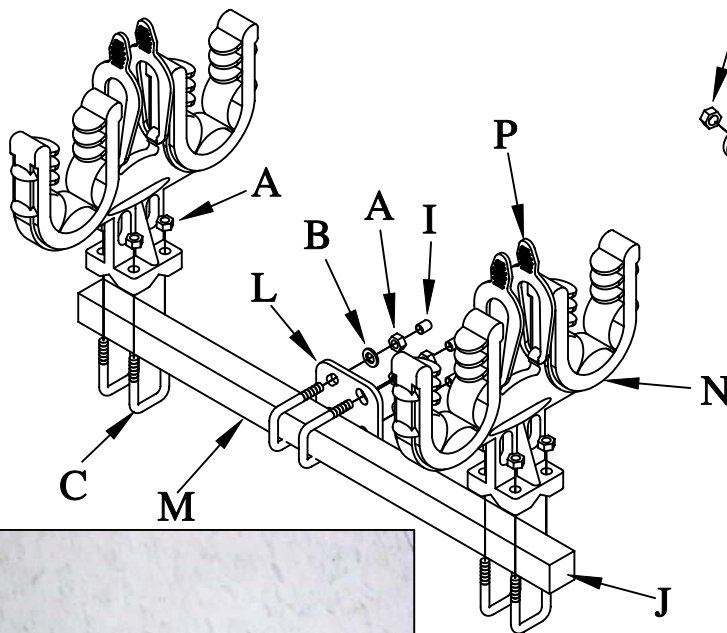

(MAIN BRACKET)

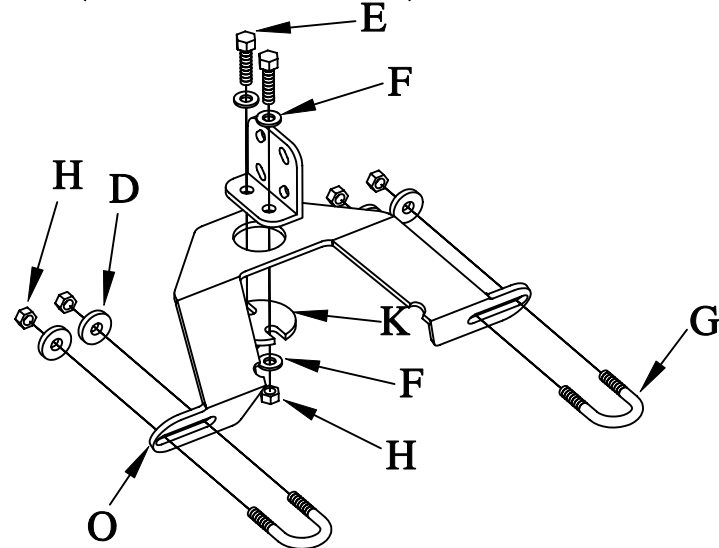

MUST REMOVE FRONT PLASTIC ON THE HANDLE BARS AND TRIM AS THE PICTURE ILLUSTRATES. THEN MOUNT THE BRACKET ON AND REPLACE THE PLASTIC.



CUT THIS SIDE 3" FROM THE END, 1" DEEP AND 2" LONG. CUT INTO A HALF A MOON SHAPE.
MAY NEED TO SLIDE THE FRONT BRAKE CALIBER OVER TO MOUNT THE BRACKET.

CUT THIS SIDE 2 1/4" FROM THE END, 1" DEEP AND 2 1/2" LONG. CUT INTO A HALF A MOON SHAPE.