

- 1=5/16 X 1 BOLTS-A
- 1=5/16 X 1 1/4 BOLTS-B
- 2=5/16 LOCK NUTS-C
- 3=5/16 USS LARGE WASHERS-D
- 1=5/16 SAE SMALL WASHER-E



#RH101

2004 HONDA RANCHERS 350S/350ES/400'S
2X4 4X4.

THIS RECEIVER HITCH WILL USE THE HITCH OFF
OF ANY AUTOMOBILE RECEIVER HITCH.

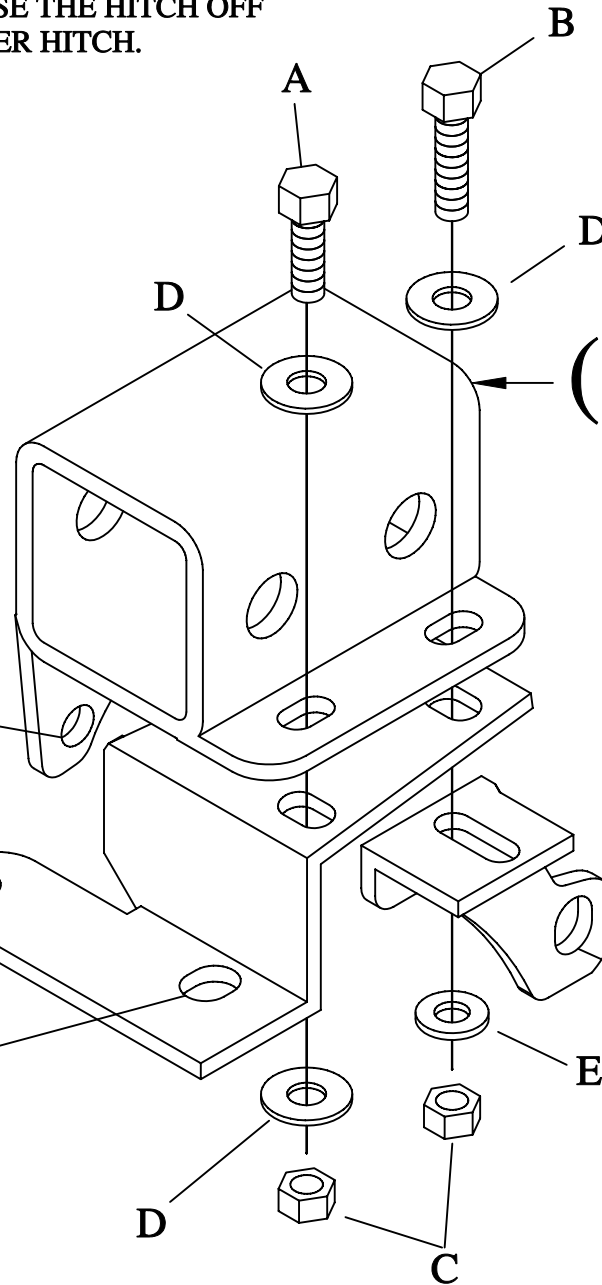

(CAUTION)

ONCE INSTALLED MAKE SURE THE TUBE THAT IS TO BE INSERTED IN THE #RH101 DOES NOT EXCEED PASS THE END OF THE #RH101. THIS IS SO NOTHING WILL HIT THE SHOCK AS THE TRAVEL MOVES ON THE REAR AXLE OF THE ATV.

USE YOUR ORIGINAL NUTS FROM YOU REAR DIFF HERE.

USE YOUR ORIGINAL HITCH NUTS AND BOLTS HERE.

USE YOUR ORIGINAL SHOCK BOLT HERE.

MUST REMOVE YOU STOCK TRAILER HITCH TO INSTALL THE #RH101. YOU WILL USE THE NUTS AND BOLTS IN THE ABOVE STEP.