

- 6=1/4X3/8 U-BOLTS-A
- 12=1/4 SAE WASHERS-B
- 12=1/4 LOCK NUTS-C
- 6=5/16 TANNER RIVETS-D
- 6=5/16 SAE WASHERS-E



# # SS140H

2003 YAMAHA KODIAK 450 4X4  
NEW VENTED STYLE.

EVEN THOUGH THE NEW BOOT GUARDS YOU HAVE PURCHASED WILL COVER MORE THAN THE ORIGINAL PLASTIC GUARDS. BOOTS HAVE BEEN REPORTED TO BE TORN IN SOME CONDITIONS .DUE TO THE TURNING RADIUS ON SOME OF THE NEWER ATVS. THE BOOT PROTECTORS HAVE BEEN MANUFACTURED SMALLER TO ALLOW FOR A TIGHTER TURNING RADIUS. SAVANT MFG. (STRONG MADE) DOES NOT WARRANTY AND TORN BOOTS.

REPRESENTS THE A-ARMS.

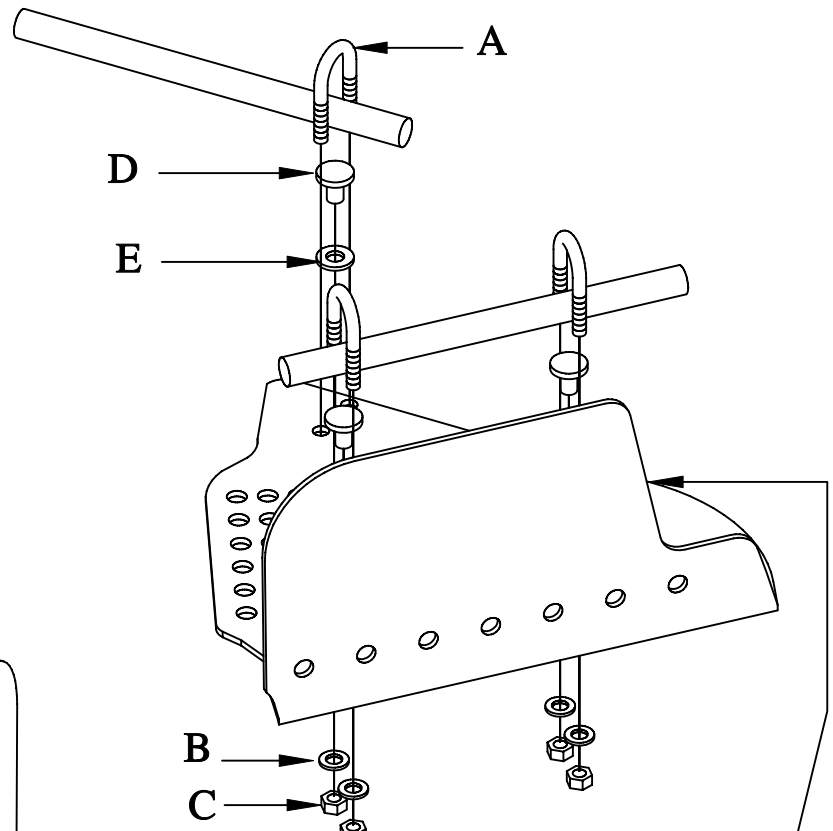
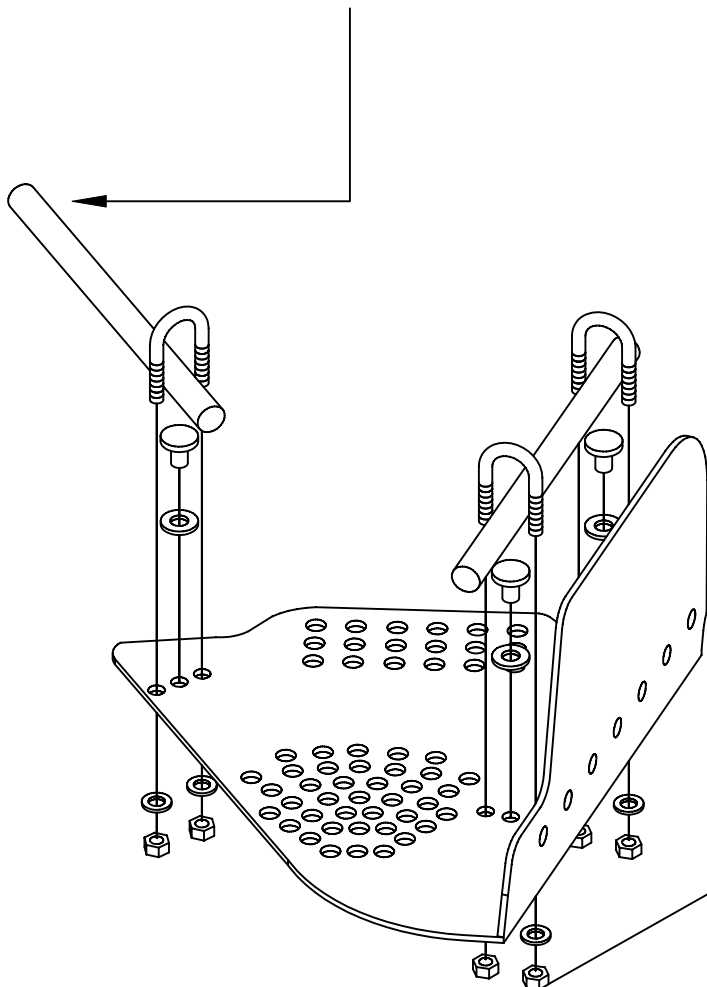

THESE ENDS WILL FACE THE INSIDE OF THE RIMS.

LEAVE THE NUTS LOOSE ON ALL THE U-BOLTS THEN SLIDE THE GUARDS UP ON THE A-ARMS TOWARD THE FRAME AS FAR AS THEY WILL SLIDE. THEN PROCEED THE TIGHTEN ALL HARDWARE.

THE SS140H WILL BOLT FROM UNDER THE A-ARMS. MUST REMOVE THE PLASTIC STOCK GUARDS TO INSTALL.