

4=1/4 X 1 YELLOW U-BOLTS-A

8=1/4 LOCK NUTS-B

8=1/4 SAE WASHERS-C

4=#16 TINNER RIVETS-D

4=5/16 SAE WASHERS-E

2=5/16 X 2 1/2" BOLTS-F

2= 5/16 LOCK NUTS-G

2=3/16 X 1 ZINC PLATED WASHERS-H

2=5/16 USS WASHERS-I



#SS144H

YAMAHA RINO 660 4X4 REAR STICK STOPPERS

REPRESENTS REAR
A-ARMS.

ONCE MOUNTED THIS END
WILL FACE TOWARD THE
REAR DIFFERENTIAL.

DO NOT OVER
TIGHTEN THIS BOLT.

THE TINNER RIVET(D) AND 5/16
WASHER(E) WILL ACT AS A SPACER
OFF OF THE A-ARMS.

THE EASIEST WAY TO
A MOUNT THE SS144H IS
TO REMOVE THE
WHEELS.

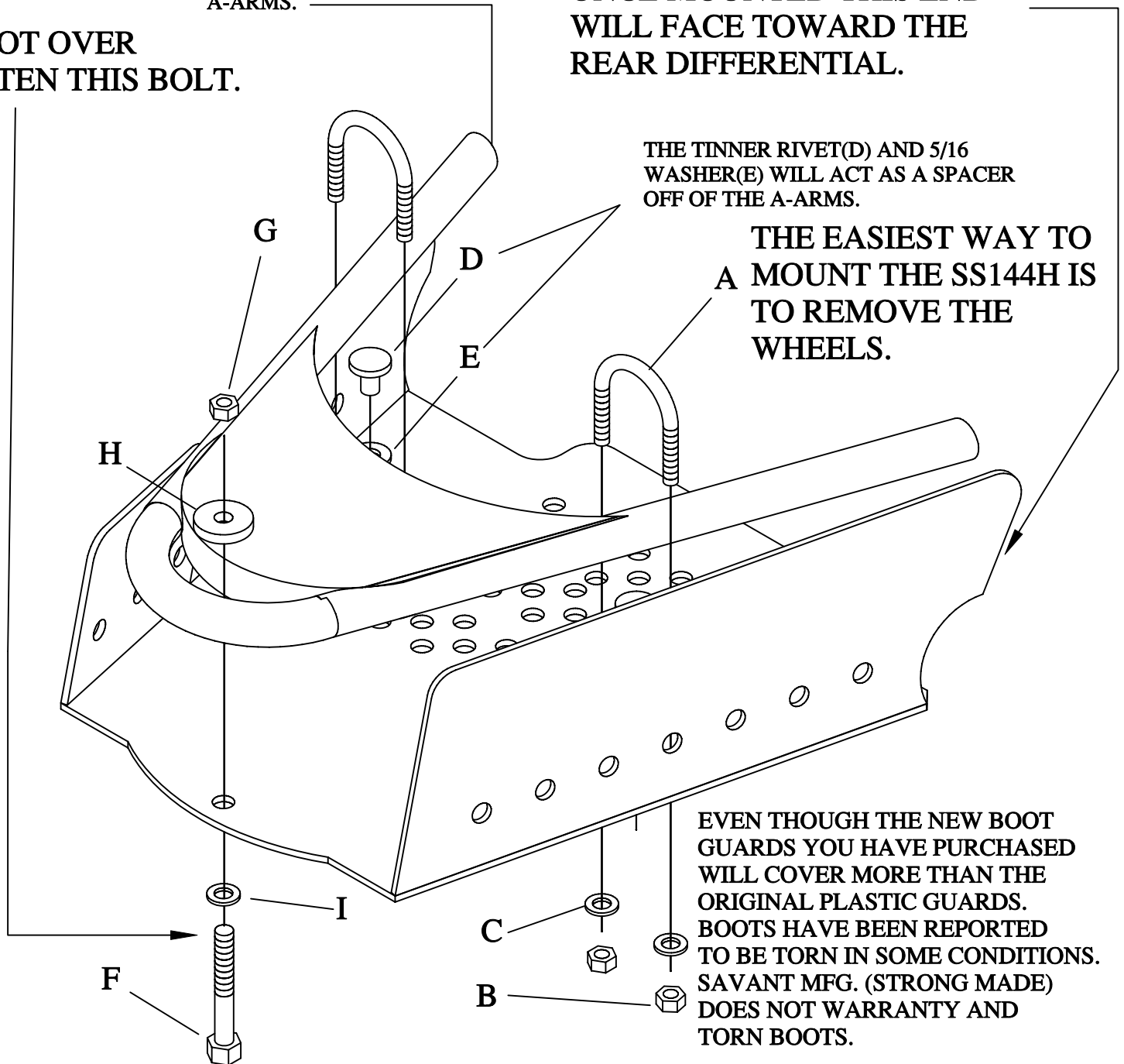

EVEN THOUGH THE NEW BOOT
GUARDS YOU HAVE PURCHASED
WILL COVER MORE THAN THE
ORIGINAL PLASTIC GUARDS.
BOOTS HAVE BEEN REPORTED
TO BE TORN IN SOME CONDITIONS.
SAVANT MFG. (STRONG MADE)
DOES NOT WARRANTY AND
TORN BOOTS.