

8=1/4X3/8 U-BOLTS-A

16=1/4 SAE WASHERS-B

16=1/4 LOCK NUTS-C

8=5/16 TANNER RIVETS-D

8=5/16 SAE WASHERS-E



#SS147H

KAWASAKI 750 BRUTE FORCE

EVEN THOUGH THE NEW BOOT GUARDS YOU HAVE PURCHASED WILL COVER MORE THAN THE ORIGINAL PLASTIC GUARDS. BOOTS HAVE BEEN REPORTED TO BE TORN IN SOME CONDITIONS .DUE TO THE TURNING RADIUS ON SOME OF THE NEWER ATV'S. THE BOOT PROTECTORS HAVE BEEN MANUFACTURED SMALLER TO ALLOW FOR A TIGHTER TURNING RADIUS. SAVANT MFG. (STRONG MADE) DOES NOT WARRANTY AND TORN BOOTS.

REPRESENTS THE A-ARMS OF THE UNIT.

NOTE: MAKE SURE THIS U-BOLT IS INSTALLED.

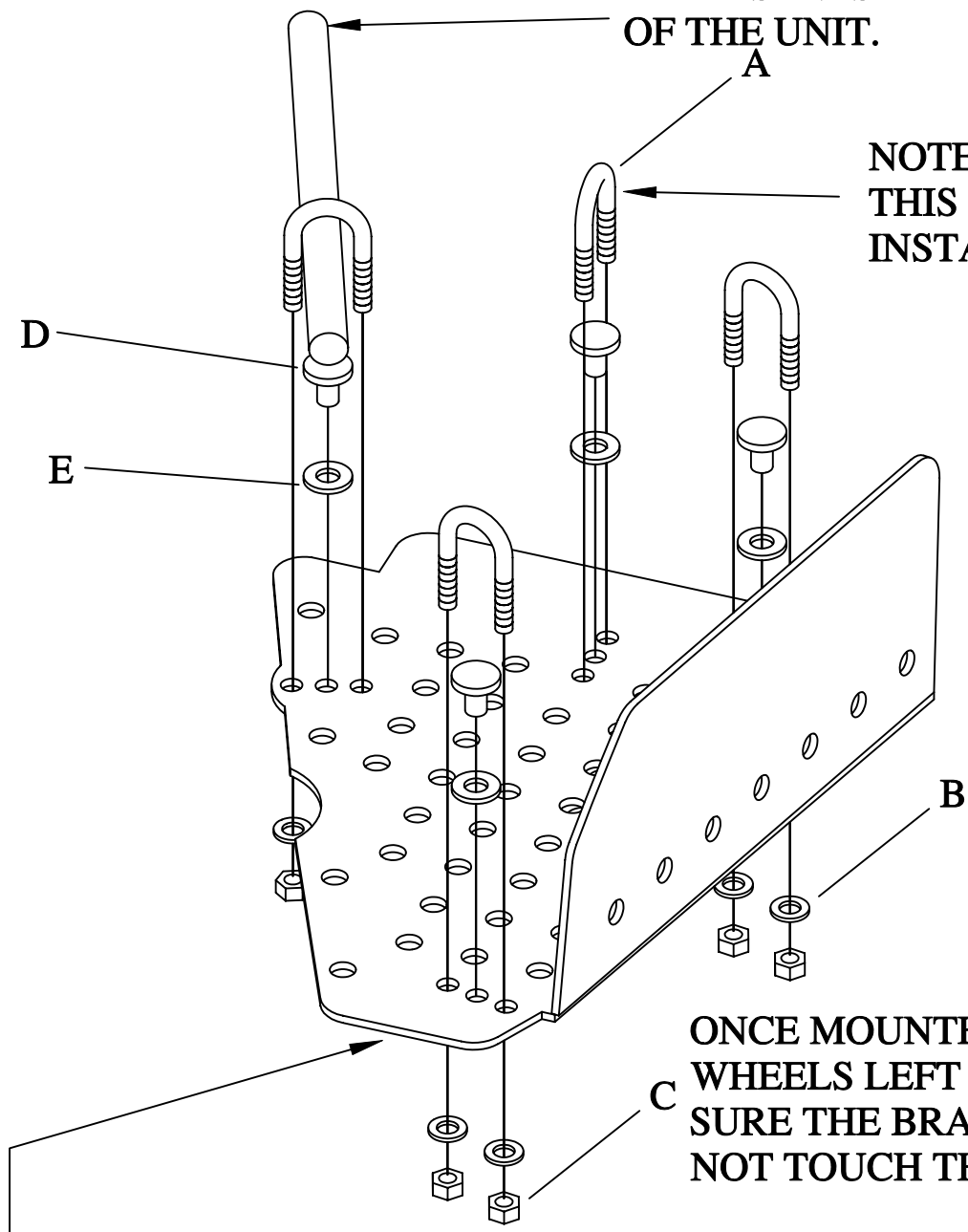

ONCE MOUNTED TURN THE WHEELS LEFT TO RIGHT MAKE SURE THE BRAKE LINES DO NOT TOUCH THE SS147H.

THIS END WILL FACE THE INSIDE OF THE RIMS ONCE THE SS147H HAS BEEN MOUNTED.