

- 6=#16 TANNER RIVETS-A
- 16=1/4 LOCK NUTS-B
- 12=1/4 SAE WASHERS-C
- 6=5/16 SAE WASHERS-D
- 4=1/4 X 1 BOLTS-E
- 6=1/4 X 1/2 U-BOLTS-F



SS173H

FRONT GUARDS POLARIS RZR 800

MUST REMOVE ALL PLASTIC GUARDS.

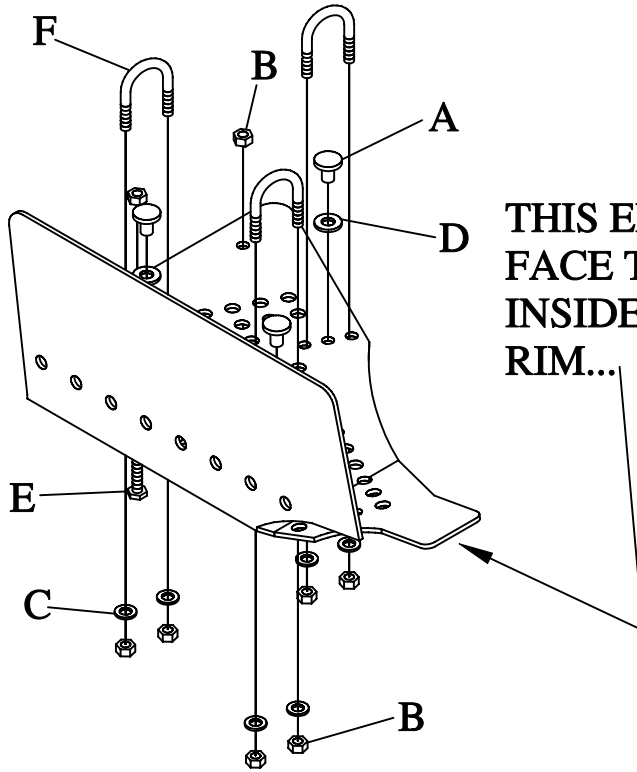

THIS END WILL FACE THE INSIDE OF THE RIM...

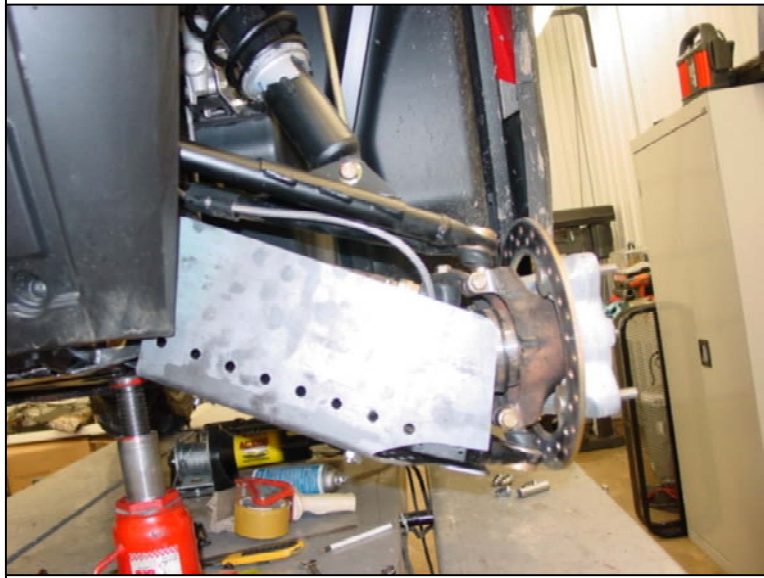

ONCE THE GUARDS HAVE BEEN INSTALLED UNDER THE A-ARMS MUST SLIDE THE GUARD UP UNTIL THESE BOLTS HAVE HIT THE BACK TUB. TOWARDS THE FRAME OF THE ARM.

